

INSTRUMENT PANEL

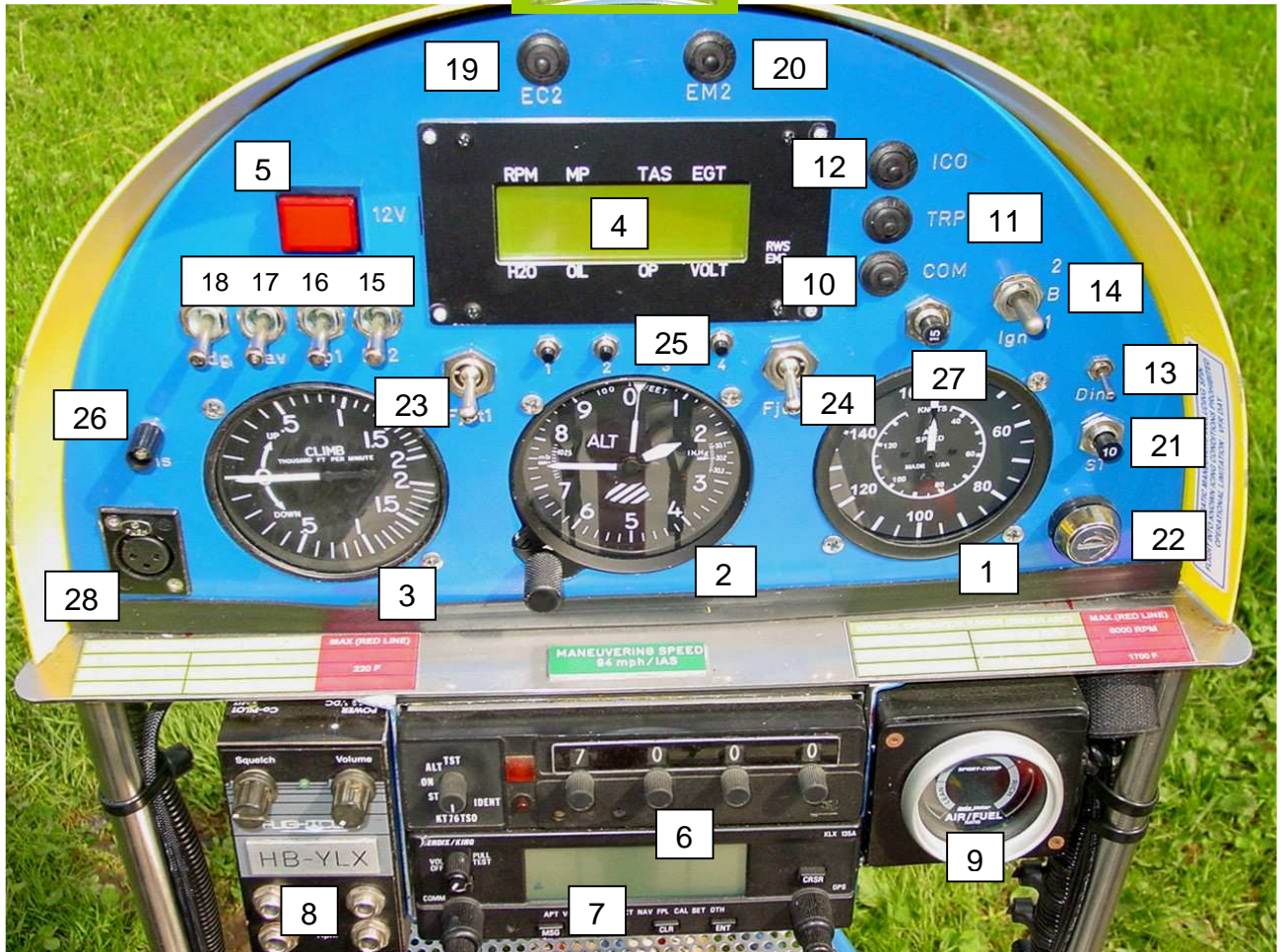

29



- |   |  |
|---|--|
| 1 Speed indicator                       | 15 Fuel pump 2 switch and CB                 |
| 2 Altimeter                             | 16 Fuel pump 1 switch and CB                 |
| 3 Vario                                 | 17 Position/Strobe light switch and CB       |
| 4 Electronic engine instrumentation EM2 | 18 Landing light switch and CB               |
| 5 Low voltage light (< 12V)             | 19 EC2 CB                                    |
| 6 Transponder                           | 20 EM2 CB                                    |
| 7 COM/GPS                               | 21 Starter CB                                |
| 8 Intercom panel                        | 22 Master key                                |
| 9 Air/Fuel mix indicator                | 23 Fuel jet 1 switch                         |
| 10 COM/GPS CB                           | 24 Fuel jet 2 switch                         |
| 11 Transponder/encoder CB               | 25 EM2 Page up, Page down, Default (1,2,3,4) |
| 12 Intercom CB                          | 26. EM2 panel contrast (Vis)                 |
| 13 EM2 panel high light (DIM)           | 27 CB 15 A for Fuel jet 1 and 2              |
| 14 Ignition 1, B, 2 switch and CB       | 28 Pilot headset power 12V                   |
|   | 29 Compass                                   |

STATIC AIR SYSTEM

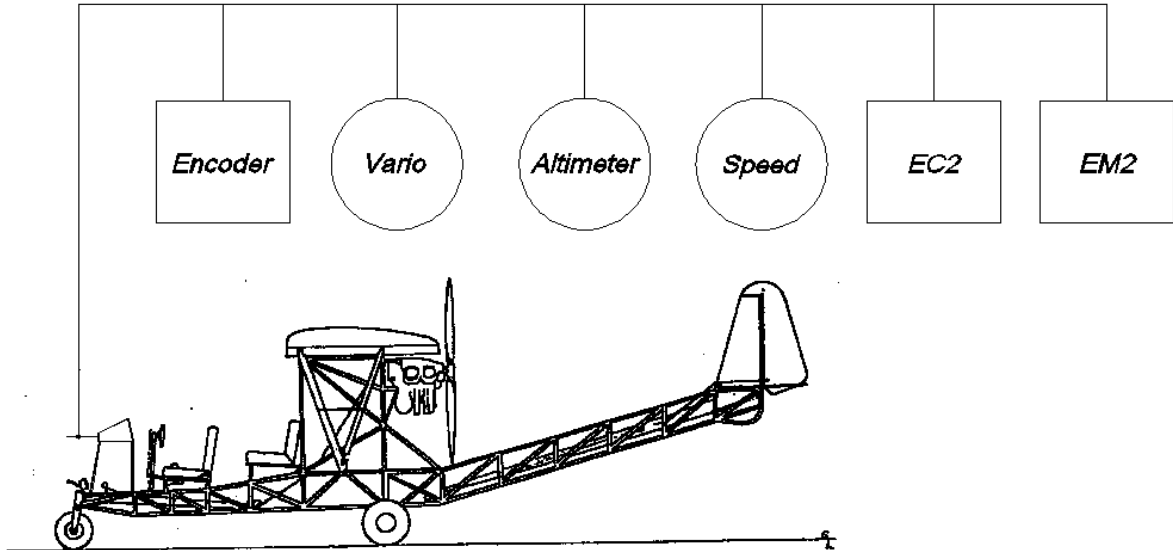

FUEL LEVEL INDICATORS

Approx. fuel quantities

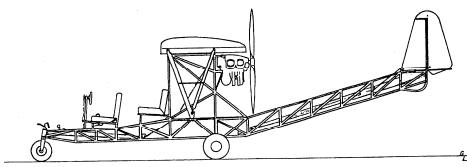
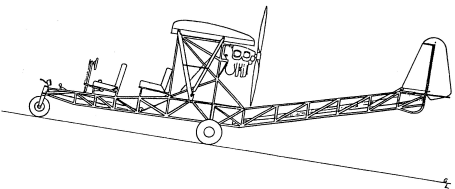
INSTRUMENT READING				
	Left Tank	Right Tank	Left Tank	Right Tank
<b>4.5 gal</b>	1/4	1/4	1/5 to 1/4	1/5 to 1/4
<b>9 gal</b>	1/2	1/2	1/2 (Little different)	1/2 (Little different)
<b>18 gal</b>	1	1	1	1

Note:for refueling convert US/GAL into liters

5 gal	10 gal	15 GAL	20 GAL	25 GAL	30 GAL	35GAL
19 Liters	38 Liters	57 Liters	76 Liters	94.5 Liters	113.5 Liters	132.5 Liters

PROGRAMMABLE INSTRUMENTS

ENGINE CONTROL SYSTEM EC2



<b>PGM VAR</b>	Program value knob	<b>Mode</b>	Select switch #0 - #9
<b>Store</b>	Prog. Store switch	<b>CLD STR</b>	Up ON / down OFF
<b>A - B</b>	A/B Select switch	<b>MIXTURE</b>	Control knob lean - rich

ENGINE MONITOR SYSTEM EM2



<b>RPM</b>	Tachometer	<b>OIL</b>	Temperature
<b>MP</b>	Manifold pressure	<b>OP</b>	Oil pressure
<b>TAS</b>	N/A	<b>WP</b>	Water pressure
<b>EGT</b>	Exhaust gas temp.	<b>H2O</b>	Temperature
<b>VOLT</b>	Voltage	<b>GPH</b>	Gallon per hour
<b>MPG</b>	Manifold pressure gage	<b>FP</b>	Fuel pressure

Note: Complete operation features are shown in the engine control manual.